

12 Activities to help you **PREPARE** for the next **COVID** phase and other disasters.



Pick one item per day, one per week, or one per month to create an emergency action plan.



Table of Contents

Activity 1:	Action Plans	3
	Earthquake, Tsunami	3
	Flooding	4
	Wildfire, Chemical Release	5
Activity 2:	Out of Area Contacts	6
Activity 3:	Water	8
	Water, Food First Aid	9
Activity 4:	Storage Kits	10
	Storing Emergency Supplies	10
	Tools & Supplies, Special Items, Clothing/Bedding	11
Activity 5:	Important Documents	12
Activity 6:	Extended Event Supplies	13
	Lighting, Cooking, Shelter	13
	Power Outage	14
	Sanitation, Pets, Emergency Information	15
Activity 7:	Under-The-Bed Items	16
	Ready to Respond Day or Night, Under the bed items	16
Activity 8:	Utility Safety	17
	Natural Gas	17
	Water, Electricity	18
Activity 9:	Drop-Cover-Hold	19
	Earthquake Drills	19
Activity 10:	Fire Safety	20
	Fire Extinguishers	20-21
	A Fire Following an Earthquake	21
Activity 11:	Shelter In Place	22
	Shelter in Place Instructions	23
Activity 12:	Home Hazard Hunt & Earthquake Home Hazards	24-27
Notes	28-29
Help-OK Signs	30-31
For More Information	32

ACTION PLANS

Earthquake:

An earthquake is a sudden release of pent-up energy along a fault line in the earth's crust. Without warning, the ground under your feet will begin to shake and roll.

A timely response is critical. Gas leaks may have occurred, which could lead to fire and explosion. People may have been injured. What you do in the *first hour* following an earthquake can save lives, reduce the severity of injuries, and save property.

What To Do: During Earthquake

1. If inside, drop, cover and hold on under a table.
2. If outside, move away from buildings, street lights, etc. and drop, cover, and hold on in clearing

After Earthquake

1. Check on the well-being of your loved ones.
2. Dress for safety - protect your head, hands, and feet. Sturdy shoes will protect your feet from broken glass. Leather gloves will protect your hands from sharp debris. A hard hat will protect your head from fallen objects, like chimney bricks teetering on roof edges. (**See Activity #7 –Under the Bed**, for more information.)
3. Check your natural or propane gas and shut it off if necessary. (**See Activity #8 - Utility Safety**, for more information.)
4. Shut off your water at the house master shut-off valve. If water pipes have broken, this will help keep the water in your water heater safe from pollutants. (**See Activity #8 - Utility Safety**, for more information.)
5. Post an OK/Help card in your front window or on your front door. If you – or a neighbor – have been injured and are going into shock, time is critical. This signals your status to your neighbors and helps prioritize your response activity. (**See back two pages of this booklet.**)
6. Place your fire extinguishers outside on the sidewalk or street edge so they are visible and available for immediate use should anyone in the neighborhood experience fire. Time is critical. In a disaster, 9-1-1 fire responders will likely be unavailable.

Tsunami:

- Tsunamis that strike the West Coast are most often caused by earthquakes. These earthquakes might occur far away or near where you live.
- Some tsunamis can be very large. In coastal areas their height can reach 30 feet or more (100 feet in extreme cases), and they can move inland from several hundred feet to a couple of miles depending on terrain.
- A tsunami consists of a series of waves. Often the first wave may not be the largest. The danger from a tsunami can last for several hours after the arrival of the first wave.
- Tsunamis move faster than a person can run.
- Sometimes a tsunami causes the water near the shore to recede, exposing the ocean floor.
- The force of some tsunamis is enormous. Large rocks weighing several tons along with boats and other debris can be moved inland hundreds of feet by tsunami wave activity. Homes and other buildings are destroyed. All this material and water move with great force and can kill or injure people.

What To Do:

- If you are at the beach and hear there is a tsunami warning, make sure your entire family is aware of the warning. Evacuate immediately.
- If you feel the earth shake, move immediately to higher ground, DO NOT wait for a tsunami warning to be announced.

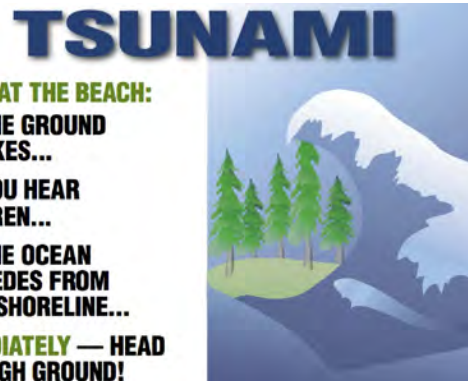

Flooding:

Floods can be serious catastrophes and they are one of the most common hazards in the United States. Floods can be caused by a variety of factors, including a sudden accumulation of rain, rising rivers, tidal surges, ice jams snow melt, and dam failures. You will likely hear weather forecasters use these terms when floods are predicted in your community:

- Flood/Flash Flood Watch—Flooding or flash flooding is possible in your area.
- Flood/Flash Flood Warning—Flooding or flash flooding is already occurring or will occur soon in your area.

Before a flood

- Plan for evacuation including where you are going to go and the route you will follow.
- Purchase flood insurance if needed in your area.
- Keep all insurance policies and a list of valuable items in a safe place.
- Take photos or a videotape of the valuables you keep in your home.
- Keep your vehicles filled with fuel.
- Listen to your radio or television for reports of flood danger.
- Consider placing sandbags in vulnerable locations around your home.

During a flood

- Grab your Grab-n-Go Kit (**See Activity #4 – Grab-n-Go Kits**)
- Move immediately to higher ground or stay on high ground.
- Evacuate if directed.
- Avoid walking or driving through flood waters. Turn Around, Don't Drown! Water can be deeper than it appear and water levels rise quickly. Just 6 inches of moving water can knock you down and 2 feet of water can sweep your vehicle away. If your car stalls in floodwater, get out quickly and move to higher ground.
- Stay away from disaster areas unless authorities ask for volunteers.
- Stay away from downed power lines.
- Be especially cautious at night when it is harder to recognize flood danger.

- Wash your hands frequently with soap and clean water if you come in contact with floodwaters.

After a flood

- Return home only when authorities say it is safe.
- Be aware of areas where floodwaters have receded and watch out for debris. Floodwaters often erode roads and walkways.
- Do not attempt to drive through areas that are still flooded.
- Avoid standing water as it may be electrically charged from underground or downed power lines.
- Photograph damage of your property for insurance purposes.
- Wear gloves and boots when cleaning up.



Wildfire:

What - A wildfire is an unplanned, unwanted fire burning in a natural area, such as a forest, grassland, or prairie. Wildfires can damage natural resources, destroy homes, and threaten the safety of the public and the firefighters who protect forests and communities.

When - Wildfires can occur at any time throughout the year, but the potential is always higher during periods with little or no rainfall, which make brush, grass, and trees dry and burn more easily. High winds can also contribute to spreading the fire.

Where - Wildfires can occur anywhere in the country. They can start in remote wilderness areas, in national parks, or even in your backyard. Wildfires can start from natural causes, such as lightning, but most are caused by humans, either accidentally— from cigarettes, campfires, or outdoor burning—or intentionally.

What To Do:

If told to evacuate, or threatened by fire:

- Grab your Grab-n-Go Kit
- **(See Activity #4 – Grab-n-Go Kits)**
- Evacuate immediately. Follow designated evacuation routes.
- Meet with family members at pre-determined meeting location.
- Keep tuned to a NOAA radio or a local emergency alert station for updates.

When leaving the house:

1. Shut all windows but leave them unlocked.
2. Remove flammable window shades and curtains.
3. Move flammable furniture to center of room, away from windows and doors.
4. Shut gas off at the meter.
5. Turn pilot lights off.
6. Leave house lights on for visibility.
7. Shut off air conditioning.
8. Don't forget your pets!



Chemical Release or Volcanic Ash Fall:

A chemical release is an accidental release of harmful chemicals into the air. It can occur at manufacturing plants, or from accidents involving transport trucks or trains. They can also be the result of terrorist acts and those intending to create harm and injury. The same procedures would be used for volcanic ash fall.

Shelter In Place (Stay where you are)

1. Go inside immediately. Remember your pets.
 2. Tightly lock all doors and windows.
 3. Shut off fans and all devices that circulate air throughout your home.
 4. Go into your pre-selected room and tightly seal it with plastic sheeting and duct tape. Place a dampened towel under the door.
- (See Activity #11 - Shelter in Place.)**
5. Listen to the radio for instructions.
 6. Thoroughly air out your home once the emergency is over.

In Your Car

1. Tightly roll up all windows.
2. Shut off the motor to avoid drawing outside air in through the engine.
3. Turn off all heating and cooling and close all vents.
4. Breathe through a dampened cloth.
5. Turn on the radio and listen for instructions.

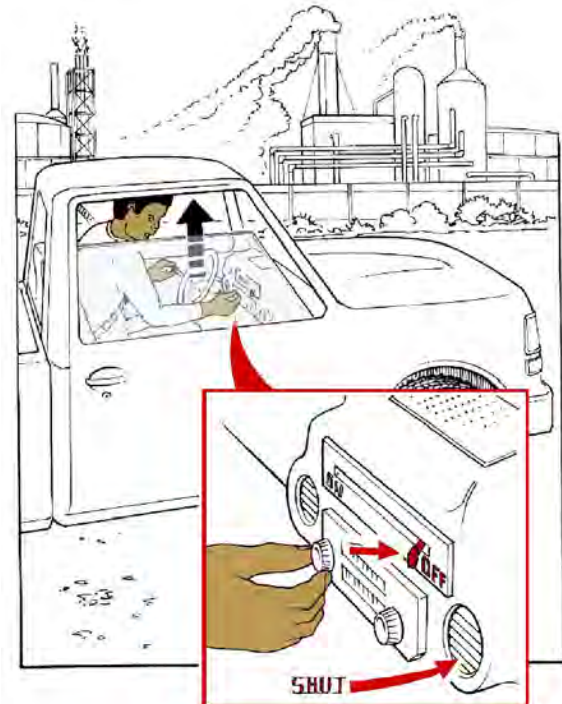

Activity #2

Out-of-Area Contacts

Preparing to be Separated From Loved Ones

If you are separated from your loved ones when disasters strike, you will wonder how and where they are. The stress of the event may make it difficult for you to remember routine information, like phone numbers. Consequently, we recommend that every household member have an out-of-area contact card in your possession at all times.

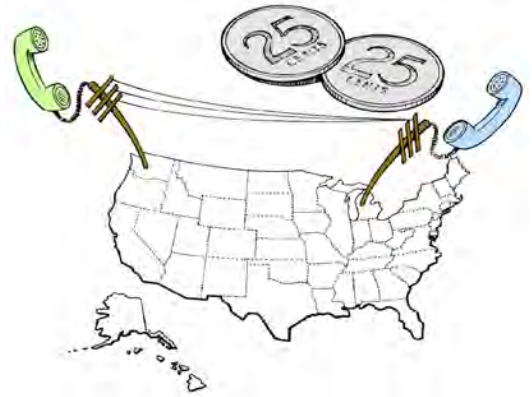

Contacting loved ones after disasters:

1. Ask an out-of-area friend to be your contact person.
This person should live at least 100 miles away from you.

After a disaster, it can be much easier to reach someone out-of-area not impacted by the same disaster. Cell phones may not be able to make calls however the text message capabilities often work as it doesn't take up as much time on the system.

Out-of-area contact:

Phone Number:



After a disaster, all household members call this person to tell her or him how they are, and to find out how other household members are.

OUT OF AREA CONTACT PERSON
WHY? Local phone systems may be shut down in a disaster.
However, you frequently can place a long-distance call.

Name (print):

Phone number (with area code):

Cell phone number (with area code):

TIP: You may be able to text message all your loved ones on your cell phone. Keep these messages short.

2. Make small cards with this person's name and phone number for all family members to carry in their wallets, purses, or backpacks.

OUT OF AREA CONTACT PERSON
WHY? Local phone systems may be shut down in a disaster.
However, you frequently can place a long-distance call.

Name (print):

Phone number (with area code):

Cell phone number (with area code):

TIP: You may be able to text message all your loved ones on your cell phone. Keep these messages short.

OUT OF AREA CONTACT PERSON
WHY? Local phone systems may be shut down in a disaster.
However, you frequently can place a long-distance call.

Name (print):

Phone number (with area code):

Cell phone number (with area code):

TIP: You may be able to text message all your loved ones on your cell phone. Keep these messages short.

OUT OF AREA CONTACT PERSON
WHY? Local phone systems may be shut down in a disaster.
However, you frequently can place a long-distance call.

Name (print):

Phone number (with area code):

Cell phone number (with area code):

TIP: You may be able to text message all your loved ones on your cell phone. Keep these messages short.

Print these cards - cut apart and prepare one for each loved one.

Activity #3

Water

Preventing thirst after a disaster

Water is essential for survival. The ground trembling and shaking caused by earthquakes can crack or break the lines that bring fresh water to your house. You may have to rely for ten days or more on the water you have stored.

How much water should I store?

One gallon per day for each person in your household is the minimum amount required to take care of drinking, cooking, and hygiene needs for the first 10 days of a disaster.



Which containers are good?

Plastic containers with a screw-cap lid, such as two-liter soda pop bottles or food-grade plastic jugs, work great.

If you use two-liter soda pop bottles, plan to store at least twenty (20) of these for each person in your household.

There are 5, 30 and 55 gallon water storage rated drums available also; these are good to store larger quantity water in garage.

Camping water storage containers work great and usually hold 5-7 gallons per container.

Avoid the use of plastic milk jugs. They are difficult to seal tightly, and their plastic becomes very fragile and brittle over time.

Storing water

1. Choose containers that have a tight-fitting screw-cap lid. Two-liter pop bottles are a great choice.



2. Thoroughly rinse out the container and the lid with water and **fill it to the very top** of the container. For extra safety, thoroughly rinse the container with a weak solution of liquid chlorine bleach (8-10 drops in two cups water). Empty this solution out and fill the container right to the top with fresh water.

3. Seal the container tightly.

4. Label it "drinking water" and date it.

5. Store it in a cool, dark place. Examples:

- Under the bed
- In the corner of closets
- Behind the sofa

Hint: To make it easy to find many places to put your water, think about this activity as a priority rather than an inconvenience.

Can I improve the taste of stored water?

Stored water will taste better if you put oxygen back into it by pouring the water back and forth between two clean containers several times.

Is adding liquid bleach recommended?

In March 1994, the Food and Drug Administration and the Environmental Protection Agency stated:

• Tap water does not need anything added to it before it is stored because it has already been chemically treated.

• Commercially purchased water does not need anything added to it. Keep it in its original, sealed container.

NOTE:

Your hot water heater is a great source of drinkable water. Just use the drain.

What about rotation?

It is recommended that water be rotated every six months.

Treating water of questionable purity:

1. Filter the water to remove as many solids as possible. Coffee filters, cheesecloth, or several layers of paper towels work well.
2. Bring the water to a rolling boil for **ONE** full minute.
3. Let it cool for at least 30 minutes. Water must be cool or the chlorine you add next will dissipate and be rendered useless.
4. **Add 1/8 teaspoon of liquid chlorine bleach per gallon** of cool water, or **8 drops per two-liter bottle**. The only active ingredient in the bleach should be 6.00% sodium hypochlorite, and there should be no added thickeners, soaps or fragrances.
5. Let it stand for 30 minutes.
6. If it smells of chlorine, you can use it. If it does not smell of chlorine, add 16 more drops of chlorine bleach per gallon, let it stand for another 30 minutes, and smell it again. If it smells of chlorine, you can use it. If it does not smell of chlorine, discard it and find another source of water.

Distillation - A second method of purification:

1. Fill a pot halfway with water.
2. Tie a cup to the handle on the pot's lid so that the cup will hang right-side up when the lid is placed upside-down on the pot (make sure the cup is not dangling in the water).
3. Boil the water for 20 minutes. The water that drips from the lid into the cup is distilled. This method allows the vapor resulting from boiling water to collect in the cup. This condensed vapor will not include salts or other impurities.

Water Filtering:

Filtering water is not the same as purifying water, filters remove particles and sediment, while purifiers kills bacteria and virus'. Filters are ok to use in areas known to be free from viruses. You should just be aware of your water supply and determine if filtering is an option. If it is, use a high quality water filter.

Additional information:

- Other chemicals, such as iodine or products sold in camping or surplus stores have a short shelf life and **ARE NOT RECOMMENDED AND SHOULD NOT BE USED**.
- Boiling water kills bacteria, viruses, and parasites that can cause illness. Treating water with chlorine bleach kills most viruses but will probably not kill bacteria. Therefore, boiling and then adding chlorine bleach is an effective water purification method.
- The only accepted measurement of chlorine is the drop. A drop is specifically measurable. Other measures, such as "capful" or "scant teaspoon" are not uniformly measurable and should not be used.
- There is no difference in the treatment of potentially contaminated water that is cloudy or that which is clear.

SOURCE: FDA and EPA Report, 1994



Distillation is an effective method of water purification.

Activity #4

Grab-n-Go Kits

Storing Emergency Supplies

Chances are you will have to rely upon supplies you have available in your home for at least the first 10-14 days following any major disaster.

Store these items in something that is portable and easily carried, like a plastic tub with a tight-fitting lid. In the event of fire or rapid evacuation, you'll

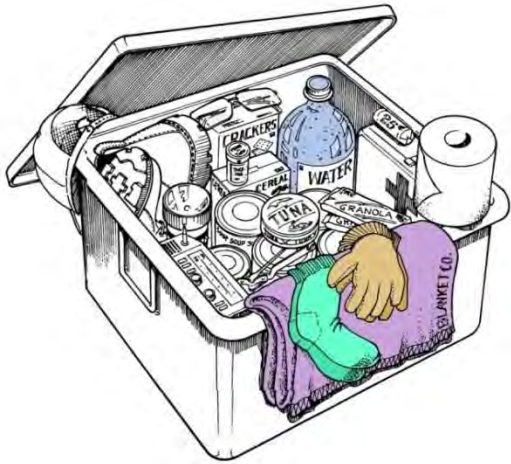

appreciate having more than just the clothes on your back. The container should be able to withstand moisture, insects, and some abuse when the quake happens. If you have a large family, several smaller tubs may be easier to carry than one large container.

Place items in plastic bags to protect against condensation, which causes mildew and rust. The bags newspapers come in are a good choice - these can later be used for disposing of waste.

Locate these supplies as close to your primary house exit as possible. You may have to find it in the dark or after the upheaval of an earthquake.

Water

Keep at least a ten-day supply of water for each person in your household. Two-liter soda pop bottles work great. That means twenty-two-liter bottles per person. (See page 8 for more information on storing water.) You can store less water per person if you have a supply of water and a filtration system, your supply could be a creek,

pond, hot water heater, melted ice, etc. just remember to have a quality water filtration system and only use when the source of the water has no bacteria or viruses', in this case, we recommend having at least a couple of gallons per person stored in the house to get started with.

Food

Store at least a ten-day supply of non-perishable food. Select foods that require no refrigeration or cooking, and little or no water.

- canned meats, fruits, and vegetables
- canned juices and soups
- high energy foods – peanut butter, granola bars, trail mix, beef jerky
- “comfort” foods – cookies, hard candy, etc.
- Dehydrated and freeze-dried are great for this.

First Aid Supplies (Starter Kit)

Customize the kit as you see fit.

- sterile 4" adhesive bandages
- sterile 4" x 4" gauze pads
- 4" rolled gauze bandages
- large triangular bandages
- butterfly bandages
- adhesive tape
- scissors and tweezers
- moistened towelettes
- bar soap
- latex gloves
- aspirin & non-aspirin pain reliever
- antacid
- anti-diarrhea medication
- insect repellent
- hydrogen peroxide to disinfect wounds
- antibiotic ointment to dress wounds
- sunscreen
- safety pins
- needle & thread
- plastic bags
- sanitary pads
- instant cold packs
- pocket knife
- splinting materials



Tools & Supplies

- paper cups, plates, and plastic utensils
- battery-operated/hand crank AM radio
- extra batteries
- flashlight
- non-electric can opener
- ABC fire extinguisher
- whistle
- toilet paper and towelettes
- liquid soap
- feminine supplies
- roll of plastic and duct tape to seal broken windows
- cash

Special Items

- extra eye glasses
- prescription drugs and medications
- baby diapers, food, and formula
- a family pictures
- games and books
- copies of insurance policies
- bank account numbers
- inventory of valuables
- family records
- contact lens solution
- denture adhesive

Clothing & Bedding

- one complete change of clothes
- blankets or sleeping bags
- mylar blankets
- sturdy shoes
- warm socks
- hat and leather gloves

Preparing for disasters is a long-term goal. To make this task manageable, choose two or three items that you need over the next 6 months.

Month #1 items to buy

Item 1:

Item 2:

Month #2

Item 1:

Item 2:

Month #3

Item 1:

Item 2:

Month #4

Item 1:

Item 2:

Month #5

Item 1:

Item 2:

Month #6

Item 1:

Item 2:

***Plan to rotate the items in your kit seasonally.
Make sure the clothes still fit.***



Important Documents

Preparing to Recover

After a major disaster, you may need financial assistance and will want to document any property loss for insurance and income tax purposes. Having ready access to the documents necessary for completing application forms, as well as those which could be difficult to replace, will help reduce delay and frustration.

At A Minimum:

1. Gather property insurance papers (home, auto, boat, etc.) and make copies.
2. Gather health insurance papers (medical provider, dental provider, life, extended disability, etc.) and make copies.
3. Gather financial papers (bank, investment, retirement, etc.) and make copies.
4. Gather wills, powers of attorney, and estate papers and make copies.
5. Take photos or videos of all valuables as documentation for insurance claims.
 - Store these copies and photos in a safe deposit box, or in a ziplock bag in your freezer (you may want to disguise these documents by putting them in a clean box like a shoe or hat box).

Important Contact Information

Because it may be difficult to think during the stress of a disaster, and because normal routines have been disrupted, take a few moments and create a written record of these important phone numbers:

Work

Adult name: _____
Place of work: _____
Work phone: _____
Cell phone: _____

Adult name: _____
Place of work: _____
Work phone: _____
Cell phone: _____

Adult name: _____
Place of work: _____
Work phone: _____
Cell phone: _____

School

Child name: _____
School name: _____
School phone: _____
Cell phone: _____

Child name: _____
School name: _____
School phone: _____
Cell phone: _____



Activity #6

Extended Event Supplies

Choosing comfort over inconvenience

Coping with the impact of a disaster is never fun. However, much of the inconvenience and discomfort the disaster causes can be reduced by planning alternative ways to take care of your needs.

Acquiring emergency supplies

At first glance, the lists may seem totally overwhelming. At second glance, you'll find that you probably already have many of these items especially if you do any camping.

- Check those items you already have.
- Circle those you don't have but are important to the comfort of you and your loved ones.
-  Choose two of those circled and add them to your weekly shopping list.

Lighting

Caution: The use of candles is no longer recommended as a source of emergency light.

Experience shows they are responsible for too many secondary fires following the disaster. Additionally, they are very dangerous in the presence of leaking natural gas.

- Flashlights and extra batteries
- Camping lanterns – store extra fuel, wicks, mantles and matches
- Light sticks – these can provide light for 1 to 12 hours and can be purchased at many camping supply stores
- Hand crank and/or solar flash light

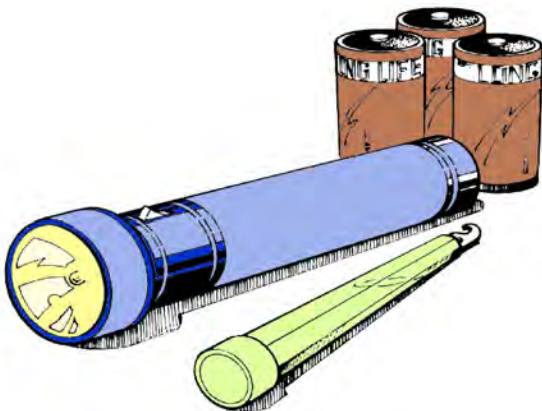

Cooking

Caution: Never burn charcoal indoors. This could cause carbon monoxide poisoning.

- Camp stoves, sterno stoves, or barbecues – store extra propane, charcoal or sterno, lighter fluid, and matches.
- Fireplaces – do not use until the chimney and flue have been inspected for cracks. Sparks may escape into your attic through an undetected crack and start a fire.
- Paper plates and cups
- Plastic utensils
- Paper towels



Shelter

It is common for people to not want to sleep in their homes for the first few days following a major earthquake. Having an alternate means of shelter will help you and your family be as comfortable as possible.

- Tent or waterproof tarp
- Sleeping bags or blankets, and pillows
- Rain gear
- Mylar blankets are compact and easy to store
- Newspapers provide insulation from the cold or heat

POWER OUTAGE Protecting stored foods when the power goes out.

- Keep refrigerator and freezer doors closed as much as possible.
- A full refrigerator will maintain safe temperatures for up to six hours.
- A full freezer will maintain safe temperatures for up to two days; a half-full freezer for one day.
- Discard at-risk refrigerated foods that are warmer than 40° Fahrenheit. If in doubt, throw it out.
- If you think the power will be out for several days, try to find some ice to pack inside the refrigerator and freezer.
- Remember to keep your raw foods separate from your ready-to-eat foods.

Foods to be concerned about

Foods are categorized into groups:

- **Potentially hazardous foods** are the most important. These include meats, fish, poultry, dairy products, eggs and egg products, soft cheeses, cooked beans, cooked rice, cooked potatoes, cooked pasta, custards, puddings, etc.
- Some foods **may not be hazardous** but the quality may be affected. These foods include salad dressings, mayonnaise, butter, margarine, produce, hard cheeses, etc.
- Some foods are **safe**. These are carbonated beverages, unopened bottled juices, ketchup, mustard, relishes, jams, peanut butter, barbecue sauces, etc.



When do I save and when do I throw out food?

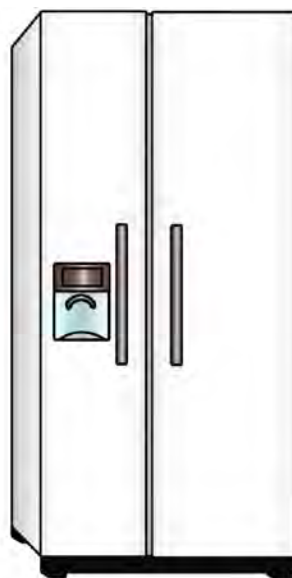

Refrigerated foods should be safe as long as the power is out no more than a few hours and the doors have been kept closed.

Potentially hazardous foods should be discarded if they warm up above 40°F.

Frozen foods which are still frozen are not a problem.

If **potentially hazardous foods** are thawed but still have ice crystals, you should use them as soon as possible.

If **potentially hazardous foods** are thawed and warmer than 40°F, you should discard them.

How do I know if the food is unsafe to eat?

- You cannot rely upon appearance or odor. Never taste food to determine its safety.
- Some foods may look and smell fine, but if they've been warm too long, food poisoning bacteria may have grown enough to make you sick.
- If possible, use a thermometer to check the temperature of the foods. If potentially hazardous foods are colder than 40°F, they are safe.

What happens when the power goes back on?

- Allow time for refrigerators to reach the proper temperature of lower than 40°F before restocking. Start with all fresh foods.

Remember - when in doubt, throw it out!

Sanitation

- The lack of sanitation facilities following major earthquakes can quickly create secondary problems unless basic guidelines are followed. If the water lines are damaged, or if damage is suspected, do not flush the toilet.

- Avoid digging holes in the ground and using these. Untreated raw sewage can pollute fresh ground water supplies. It also attracts flies and promotes the spread of diseases.

- Store a large supply of heavy-duty plastic bags, twist ties, disinfectant, and toilet paper.

- A good disinfectant that is easy to use is a solution of one-part liquid bleach to ten-parts water.

- Dry bleach is caustic and should not be used for this use.

- If the toilet is *not* able to be flushed, it can still be used. This is less stressful for most people than using some other container. Remove all the bowl water. Line bowl with a heavy-duty plastic bag. When finished, add a small amount of deodorant or disinfectant, securely tie the bag, and dispose of it in a large trash can with a tight fitting lid.

This large trash can should also be lined with a sturdy trash bag.

Eventually, the city/county will provide a means to dispose of these bags.

- Portable camp toilets, small trash cans, or sturdy buckets lined with heavy-duty plastic bags can be used. Those with tight fitting lids are best.

- Large zip-lock plastic bags and toilet paper should be kept at work and in the car for use if you are away from home. These can be wrapped in newspaper in preparation for future disposal.



Pets

Always keep a week's supply of food and water for your pet on hand.

- Toilet bowl water is an excellent supply of water for pets following an earthquake.

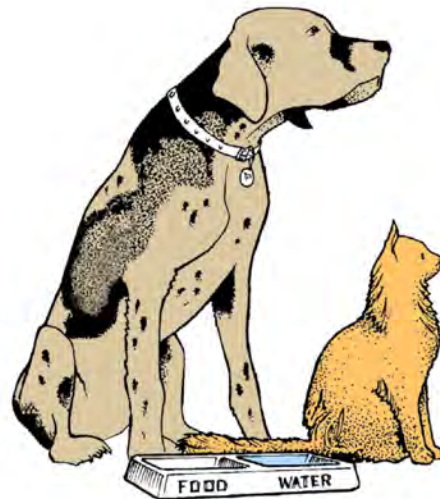

Emergency information

For the U.S. Radio Stations in your area go to:

<https://radio-locator.com/cgi-bin/finder?sr=Y&s=T&state=OR>

Be sure to obtain a battery-powered radio and a supply of extra batteries or purchase a solar hand-cranked radio.

American Red Cross - <http://www.redcross.org/>
Animal Shelters - <http://www.animalshelter.org/shelters/states.asp>

USGS Earthquake Hazards Program - <http://earthquake.usgs.gov/learn/preparedness.php>

NOAA Tsunami Preparedness- <http://www.tsunami.noaa.gov/prepare.html>

FEMA- <https://www.fema.gov/>
FEMA Mobile App - <https://www.fema.gov/mobile-app>
Centers for Disease Control and Prevention

(CDC) - <http://www.cdc.gov/>
National Weather Service- <http://www.weather.gov/>

Public Emergency Alert - <http://www.ready.gov/alerts>

Activity #7

Under-the-Bed Items

Ready to respond - day or night

When disaster strikes, it may be difficult to think as rationally and as quickly as you would like. The more procedures you have in place, and the easier they are to remember and implement, the more effective and efficient will be your response.

We recommend that you keep these basic response supplies beside or under the bed. That way, day or night, you'll know where to go to get the essentials.

At a minimum:

Keep a pair of sturdy shoes to protect your feet and a flashlight by each loved one's bed at all times.

Critical under-the-bed items

- Sturdy shoes - to protect your feet from broken glass
- Work gloves, preferably leather - to protect your hands from broken glass
- Hardhat - to protect you from falling objects like chimney bricks, and downed trees and branches
- Flashlight & light sticks - essential for a nighttime response
- An OK / Help card, found either in the MYN (Map Your Neighborhood) handout available from your local office of Emergency Management, or one that you prepare yourself
- A few Band-Aids or tape - to hang the OK / Help card in the window or on the front door

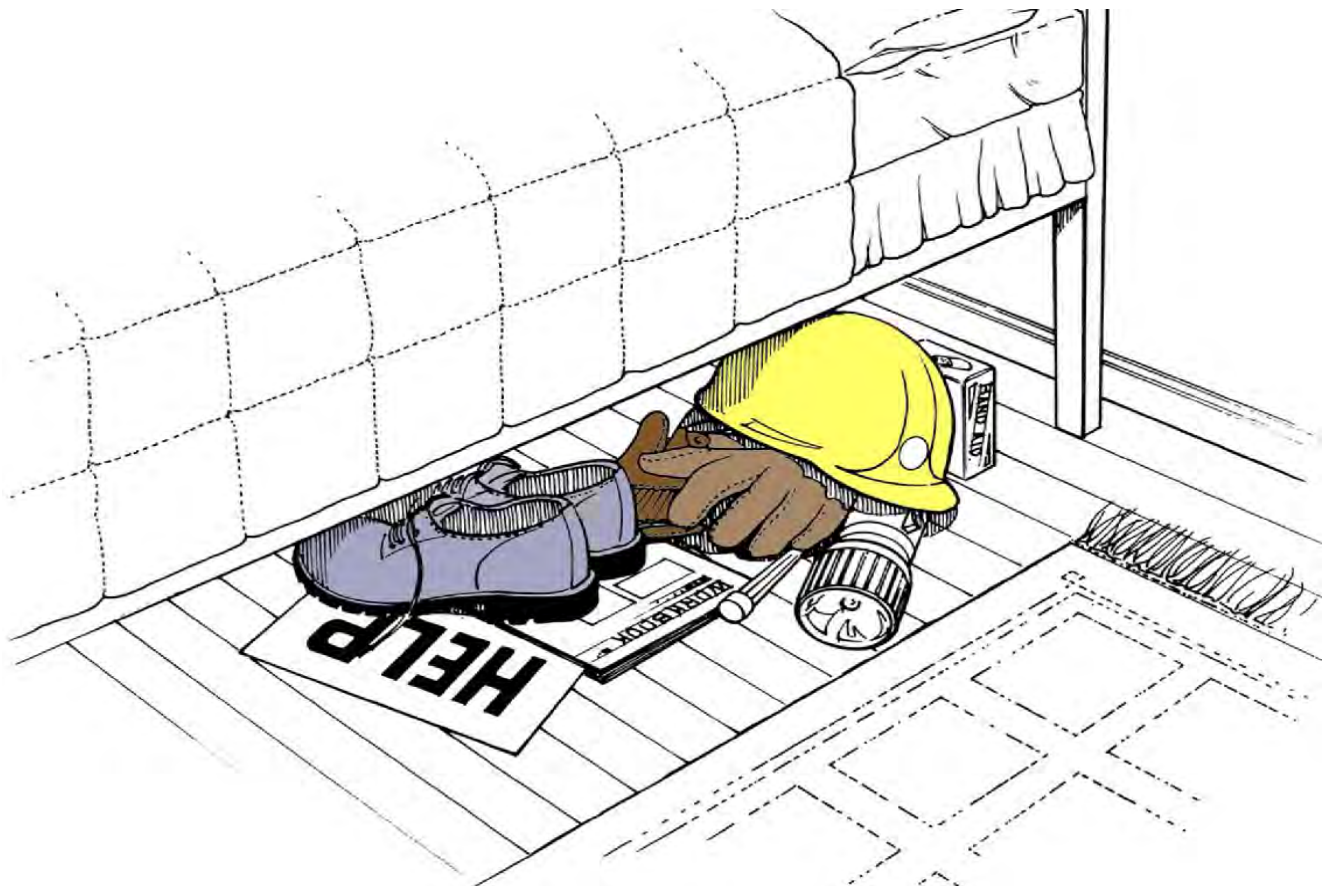

Utility Safety

Natural gas

Natural gas leaks and explosions are responsible for significant number of fires following any major earthquake. It is vital that all household members know how to shut off the natural gas.

Preparing to shut off the natural gas

- Locate the shut-off valve (see illustration). Make sure this valve will turn. To shut off the gas, turn the valve 90°, or 1/4 turn, so that it crosses the pipe (see illustration).

If your valve is rusted open, do not put WD-40™ lubricant on it. It may corrode the O-rings that allow the valve to turn.

- Attach a wrench to the meter or to the wall directly behind the meter.

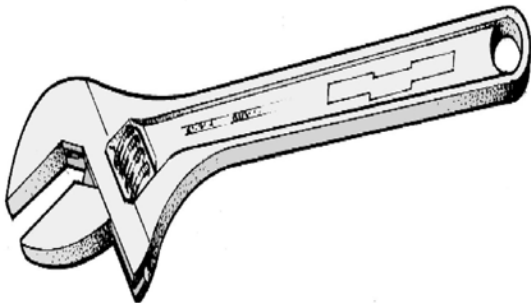

- Choose a crescent wrench that is at least 12" long
- Adjust it to fit your valve before hanging it behind the meter in case it rusts.

The 4-in-1 tool



- Shuts off gas - Shuts of water - Pries
Opens Doors - Digs Thru Debris during

Shutting off the gas after an earthquake.

- Shut off the gas immediately **only** if you smell the characteristic odor of gas, you hear a hissing sound, and/or you notice the meter dials spinning more rapidly than normal.
- Do not use matches, lighters, open flame appliances, or operate any electrical switches until you are sure no gas leaks exist. Sparks from electrical switches could ignite the gas.
- If you smell natural gas, immediately get everyone out of and away from the house.

Open the windows and doors to provide ventilation. Shut off the gas at the meter.

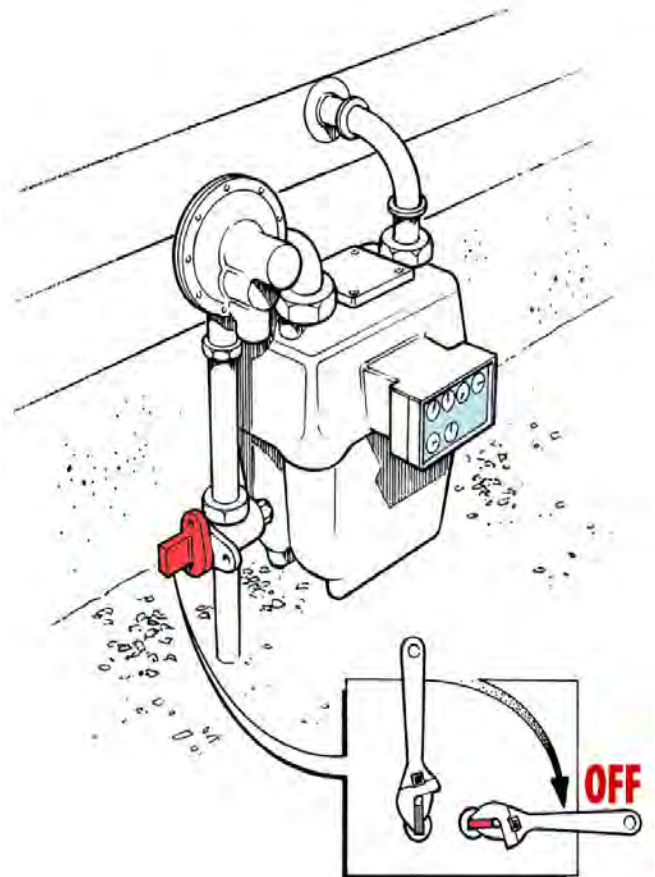

Water

Water quickly becomes a precious resource following many disasters. It is vital that all household members learn how to shut off the water at the main house valve.

- Cracked lines may pollute the water supply to your house. It is wise to shut off your water until you hear from the authorities that it is safe for drinking.
- The effects of gravity may drain the water in your hot water and toilet tanks unless you trap it in your house by shutting off the main house valve (not the street valve in the cement box at the curb – this valve is extremely difficult to turn and requires a special tool).

Preparing to shut off water

- Locate the shut-off valve for the water line that enters your house. It may look like this:

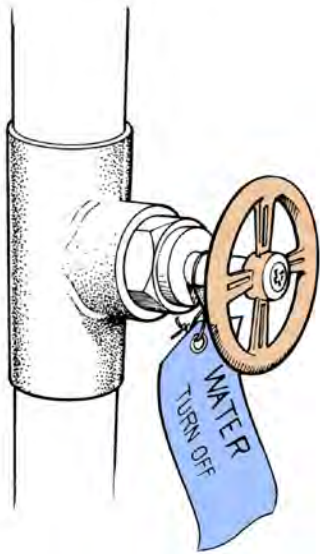

- Make sure this valve can be completely shut off. Your valve may be rusted open, or it may only partially close. Replace it if necessary.
- Label this valve with a tag for easy identification, and make sure all household members know where it is located.
- The water valve may be located in a valve box located in street or sidewalk

Electricity

Electrical sparks have the potential of igniting natural gas if it is leaking. It is wise to teach all responsible household members where and how to shut off the electricity.

Preparing to shut off electricity

- Locate your electricity circuit box.
- Teach all responsible household members how to shut off the electricity to the entire house.

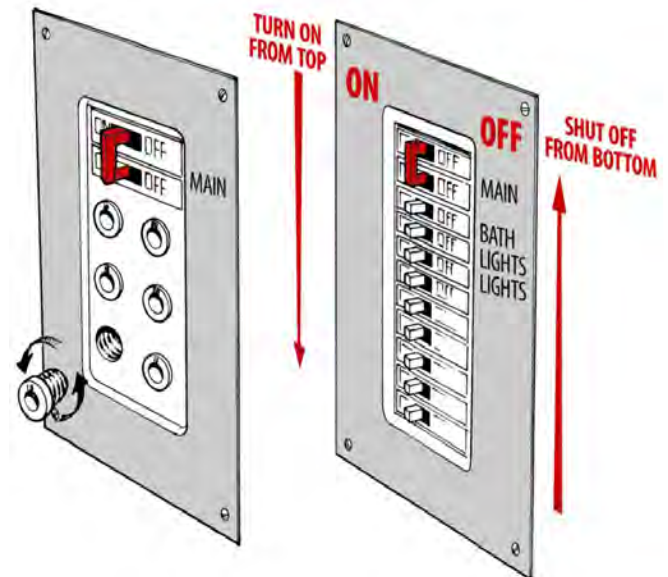

FOR YOUR SAFETY: Always shut off all the individual circuits before shutting off the main circuit breaker.

Drop - Cover & Hold On

Conquering the instinct to run

During earthquakes, many people's fight/flight instinct urges them to *run!* – even when they *know* they should “drop, cover, hold on.” Why? Rational thought (in other words, the *knowing*) flees.

Studies show that people in our country tend to be hurt by falling objects, not collapsing structures. If you are on your feet trying to move, you are in danger from toppling bookcases, breaking windows, flying dishes, falling televisions, collapsing fireplaces, or shifting furniture. Safety comes from quickly getting to a place of safety.

Practicing being safe

1. **Choose** a safe place to go in *each* room:
 - bedrooms
 - bathroom
 - living room
 - play room
 - kitchen
 - garage
2. **Practice** quickly moving to those safe place.
3. If you have to seek cover under something, make sure that it is sturdy enough to hold heavy debris.

Hold Earthquake Drills to practice taking cover in your safe places.

Regularly call out “earthquake!!” Allow everyone time to react. Then, come together and discuss where each of you went, and why it was or was not the safest place to go.

Key to Success: Practice, Practice!

Practicing is what helps ensure you will quickly move to your safe place instead of responding to the instinctive urge to run.

Drop • Cover • Hold on – What Does It Mean?

- *Drop* – under something sturdy and taller than you are
- *Cover* – the back of your head and neck with one arm
- *Hold on* – in case the thing you're under moves
- *Close your eyes* – you'll do better psychologically if you don't watch, and you'll protect your eyes

Drop • Cover • Hold on is the national standard for earthquake safety in our country. You may have read articles claiming the value of the “triangle of life.” Many of the ‘facts’ used to justify its merits are unproven and questionable. Whenever the ground begins to shake, and wherever possible, quickly take cover under a sturdy desk or table.



Activity #10

Fire Safety

Pre-planning: key to your safety

When it comes to fire – *be smart!* If the fire is too big for you to handle, immediately get out of the house. Don't stop to gather anything or to do anything. Once you are outside, stay outside. Intense heat and toxic fumes can kill you.

Planning & practicing fire safety

1. Choose a reunion place outside your home. Our fire reunion place is: _____

• Regularly remind all household members where this place is.

2. Draw the floor plan of your home, and discuss two ways to exit each room.



3. Hold a fire drill at least twice each year. Blindfolded, practice crawling to your exit routes to simulate getting out of a smoke-filled house.

Fire extinguishers

- Locate your fire extinguishers with care. Ready access to them is critical. Fire moves quickly – quick access can be the difference between putting a small fire out or suffering much damage.
- Several smaller extinguishers located throughout the house are better than one large one that may be difficult to get to quickly.

Key places for your extinguishers are:

- The kitchen
- The garage, and
- One on every level if your home has multiple floors.

A:B:C extinguishers are recommended:

"A" fires – ordinary combustibles such as wood, paper, cloth, and many plastics

"B" fires – flammable liquids such as gasoline, paints, kitchen grease, and oils

"C" fires – electrical equipment, such as fires in wiring, motors, and appliances



Check your extinguishers on a regular basis to ensure they are properly charged!

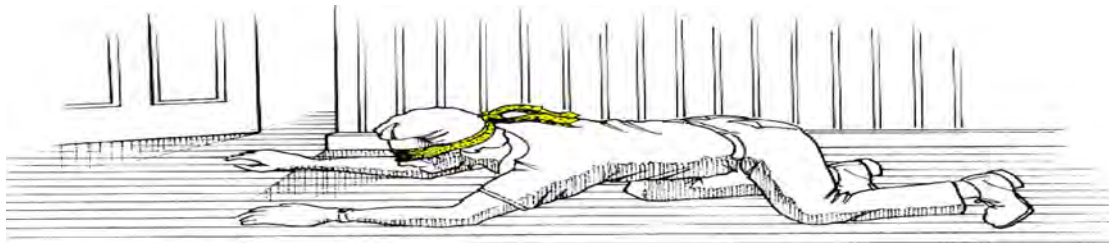

Using a fire extinguisher

- Try to keep calm.
- VITAL: Keep an escape route open between you and the *small* fire you are attempting to extinguish. If the fire is large or becomes too large, immediately get out of the house. Close the door on your way out to slow the spread of flames.
- Always point the extinguisher at the base of the fire rather than at the top of the flames.
- Remember, if the fire is too big for you to handle, immediately get yourself and your family out of the house. Don't stop to gather anything or to do anything. Seconds can make all the difference.
- Once you are outside, stay outside. Intense heat and toxic fumes can kill you in seconds.

Possible fires following earthquakes:

Natural gas fires

- First, shut off the gas.
- Second, put the fire out by using an extinguisher, dirt, or water.

Electrical fires

- First, shut off the electricity.
- Second, put out the fire by using an extinguisher, dirt, or water.

CAUTION: If the electricity cannot be shut off, **DO NOT** use water on the fire.

Oil or grease fires

- Use baking soda, a lid, a bread board, or a fire extinguisher to smother the flames. NEVER use water on a grease or an oil fire.

P.A.S.S. - a proven and effective system for putting out fire

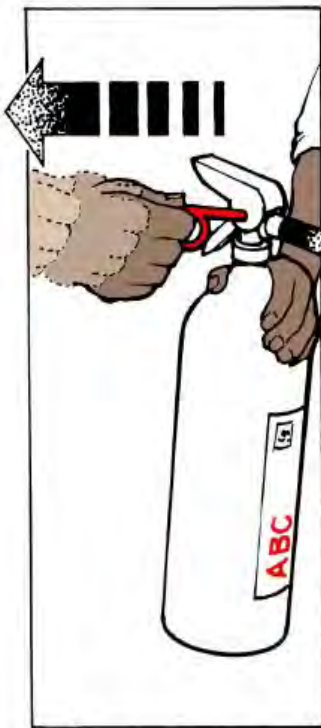

P. Pull the pin.



A. Aim at the base of the fire.

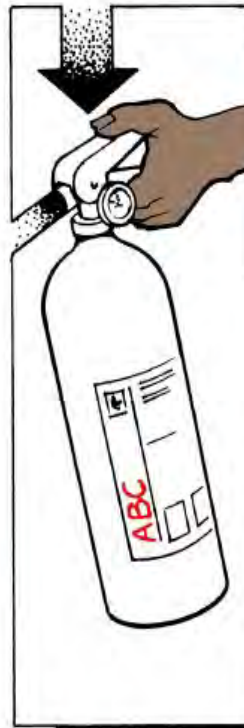

S. Squeeze the handle.



S. Sweep the hose side to side.

Shelter in Place

Creating a “Safe Room” in Your Home for Airborne Emergency’s

WHY - Your house provides a good first-layer barrier against chemical airborne agents, ash or dust. Additional protection is achieved by tightly sealing one room of your home that you have pre-designated and prepared.

WHAT - A safe room is one that easily and quickly can be sealed to protect you from airborne agents, and that has a few supplies to get you through the hours that you will need to stay inside it. All doors and windows of that room will be sealed with plastic sheeting and tape, and dampened towels or cloths will be placed under the doors. You will probably need to stay inside several hours, but not several days. So, choose a room that can accommodate your needs for several hours. A master bedroom with an attached bathroom is ideal to give you access to the toilet and running water.

Preparing a Safe Room

- Choose one room of your home that you can tightly seal.
- Purchase plastic sheeting and cloth tape or duct tape.
- Pre-cut the plastic to fit all windows, vents, and doors of this room, and label each piece
- Create a box or container to hold the pre-cut plastic, tape, and these additional supplies: a battery-powered AM / FM radio (power may be out), extra batteries, some snack foods, some water, and some towels and blankets (if this is another room than the bedroom). Store this box in your safe room.

Generally

- Shelter where you are unless directed otherwise by response officials.
- It is only natural to want to be with your loved ones, but it is safer to stay where you are. Do not attempt to get your children from school or day care.
- Typically, events of this type do not last long. The hazardous agents are moved about by air and wind, which is constantly circulating.
- In extreme cases of contamination, breathing through a wet cloth provides additional protection.

If in your car

- Tightly roll up all windows
- Shut off the motor to avoid drawing outside air in through the engine
- Turn off all heating and cooling and close all vents
- Breathe through a dampened cloth
- Turn on the radio and listen for instructions

Shelter-in-Place Instructions

1. Go inside immediately.

- Remember your pets.



2. Tightly lock all doors & windows.

- The more immediately you do this - and the more tightly - the less likely it will be that contaminants will get inside.

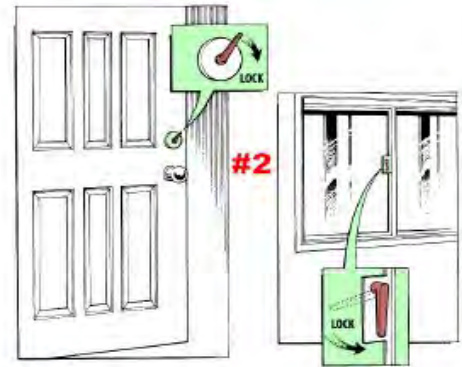

3. Shut off fans & devices that circulate air throughout your home.

- Shut off fans.
- Adjust the thermostat of furnaces & air conditioners to shut off and stay off.
- Tightly close woodstove & fireplace dampers.
- If a fire is lit, put it out, close the damper, shut the vents and doors.

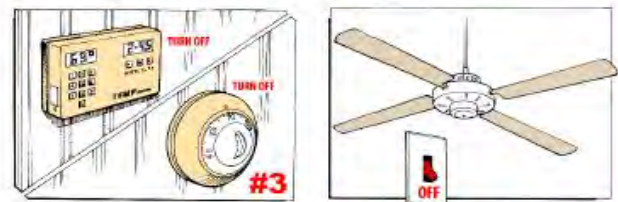

4. Go into your pre-selected room & seal it tightly.

- Tape plastic sheeting over windows, doors, vents, bathroom fans, electrical outlets, phone jacks, and TV & cable outlets. Remember - you are creating a tightly sealed room, so freely use the tape.
- Place dampened towels under door cracks to tightly seal them.

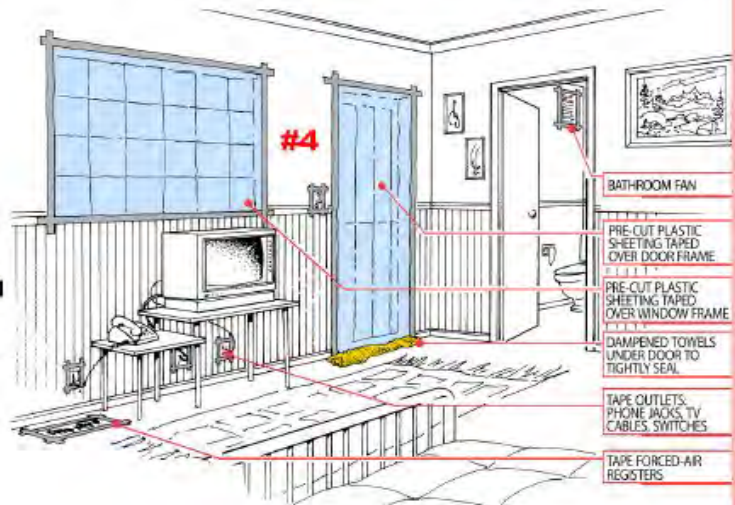

5. Listen to the radio for instructions.

- Officials will be giving instructions about whether or not to evacuate, and when it is safe to come out.



6. Thoroughly air out your home once the emergency is over.

- Open all your doors and windows. This will allow small particles that may have gotten in to dissipate.



Activity #12

Home Hazard Hunt

Identifying potential home hazards

The entire state of Oregon has the potential of being impacted by a major earthquake. Earthquakes strike suddenly and without warning. When they occur, they cause the ground to undulate and shake, perhaps violently. Buildings – and their contents – are vulnerable to this rocking and rolling. Fortunately, experts teach how to secure homes to their foundations, and contents to wall studs.

30 minutes well spent

Take 30 minutes to walk through your home. Imagine the ground movement of a significant earthquake. Identify potential hazards by completing this worksheet.

Check your water heater. Is it securely fastened to the wall studs with heavy-duty metal strapping, top and bottom (and not metal plumber's tape)?

____yes ____no

Does your water heater have flexible connectors for gas and water?

____yes ____no

Tall pieces of furniture are especially vulnerable in earthquakes. Identify each bookcase, china hutch, and armoire which needs fastening.

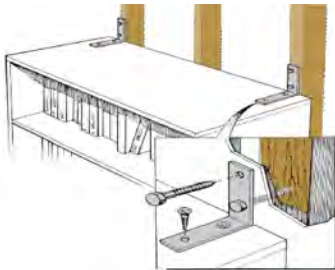

Identify heavy or breakable objects on high shelves. Pay special attention to objects with sentimental value.

(Move heavy objects that are located on high shelves to low shelves.)

Identify computers, stereos, and televisions, and microwaves and other small appliances that need to be secured.

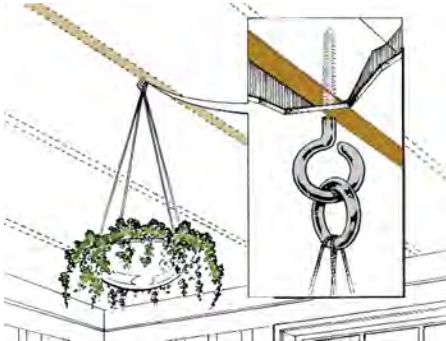

Identify hanging plants, especially in heavy baskets, and hanging lights near windows.

Identify mirrors, heavily-framed pictures, and framed artwork that needs to be secured to wall studs.

(Pay especial attention to artwork, pictures, and mirrors over beds. Consider moving these to another location.)

Identify kitchen, bedroom, and garage cabinets that need to be secured to keep their contents inside during the ground shaking.

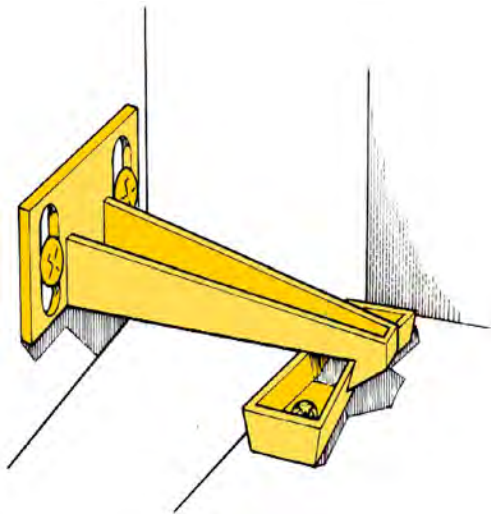

Inspect the foundation of your home. Is your home securely fastened to it?

_____yes _____no

(Check with your local city office which issues building permits for regulations.)

Does your chimney have loose bricks?

_____yes _____no

Has your attic been reinforced with plywood to help prevent chimney bricks from falling into living areas?

_____yes _____no

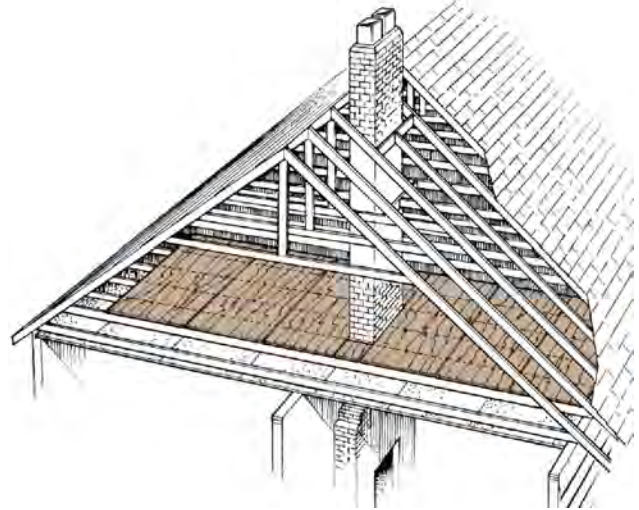

Identify poisons, toxic, or solvents in breakable containers that are located in high or dangerous locations.

In addition, check the outside of your home for hazards, such as, a leaning tree, hanging plants, decorative ornaments, etc.



Place in a window so neighbors and police know your status.

HELP

Place in a window so neighbors and police know your status.

OK

***For more information on emergency preparedness and
urban survival, go to***

decampoutdoors.com

WWW.AFROVIVALIST.COM

Special thanks to Benton County Sheriff's Office for allowing the use of the content of this booklet.
Some information has been updated and/or changed.